

Otto-von-Guericke-University Magdeburg  
Faculty of Electrical Engineering and Information Technology  
Chair for Electromagnetic Compatibility

# Degree Thesis



## Guidance on the Preparation of Degree Theses

Version 1.92, August 2025

submitted: August 20, 2025

by: John Doe  
born on January 01, 1970  
in Anytown, Country

## **Abstract**

An *abstract* is a brief summary of a research article, thesis, review, conference proceeding or any in-depth analysis of a particular subject or discipline, and is often used to help the reader quickly ascertain the paper's purpose. When used, an abstract always appears at the beginning of a manuscript, acting as the point-of-entry for any given academic paper or patent application. Abstracting and indexing services for various academic disciplines are aimed at compiling a body of literature for that particular subject [1].

## **Task of the Thesis in the Original:**

## **Declaration by the candidate**

I hereby declare that this thesis is my own work and effort and that it has not been submitted anywhere for any award. Where other sources of information have been used, they have been marked.

The work has not been presented in the same or a similar form to any other testing authority and has not been made public.

I hereby also entitle a right of use (free of charge, not limited locally and for an indefinite period of time) that my thesis can be duplicated, saved and archived by the Otto von Guericke University of Magdeburg (OvGU) or any commissioned third party (e. g. *iParadigms Europe Limited*, provider of the plagiarism-detection service “Turnitin”) exclusively in order to check it for plagiarism and to optimize the appraisal of results.

Magdeburg, August 20, 2025

# Contents

<b>1</b>	<b>Introduction</b>	<b>6</b>
<b>2</b>	<b>Guidelines for Thesis Composition</b>	<b>7</b>
2.1	Structure of the Thesis . . . . .	7
2.2	Contents of the Text . . . . .	8
2.2.1	Introduction . . . . .	8
2.2.2	Body of the Thesis . . . . .	8
2.2.3	Summary . . . . .	9
2.3	Layout . . . . .	9
2.3.1	General Page and Text Format . . . . .	9
2.3.2	Structure . . . . .	9
2.3.3	Text Layout . . . . .	11
2.3.4	Tables . . . . .	14
2.3.5	Pictures . . . . .	15
2.3.6	Lists . . . . .	18
<b>3</b>	<b>Summary</b>	<b>19</b>
	<b>Bibliography</b>	<b>20</b>
<b>A</b>	<b>Diagrams</b>	<b>21</b>
<b>B</b>	<b>Software for Using the LaTeX Document Markup Language</b>	<b>22</b>
B.1	Microsoft Windows . . . . .	22
B.2	Linux . . . . .	22
B.3	Settings for the <code>nomenc1</code> Package . . . . .	22
<b>C</b>	<b>Checklists</b>	<b>25</b>
C.1	Language . . . . .	25
C.2	Mathematical Expressions and Symbols . . . . .	25
C.3	Figures and Tables . . . . .	25
C.4	Reference and Citations . . . . .	26
C.5	Content and Structure . . . . .	26
C.6	Format . . . . .	26
<b>D</b>	<b>Project Proposal</b>	<b>27</b>

## Nomenclature

$a, A$  scalar, also complex valued

$\vec{a}, \vec{A}$  vector, also complex valued

$\eta$  effectiveness

$\kappa$  conductance

## List of Acronyms

**ISO** International Organization for Standardization

**PDF** Portable Document Format

## List of Figures

2.1	Harmonic time course of a voltage with a frequency of 50 Hz and an effective value of 230 V. . . . .	15
2.2	Two sub-figures placed side by side. . . . .	15
2.3	Two sub-figures placed one below the other. . . . .	16
2.4	Gradual JPEG artifacts example, with decreasing quality from right to left [7]	17
2.5	Example of a circuit diagram created using <i>CircuitikZ</i> . . . . .	18
B.1	Settings to use the <code>nomenc1</code> package in TeXnicCenter . . . . .	23
B.2	Settings for using the <code>nomenc1</code> package in Texmaker . . . . .	23
B.3	Function <code>Quick Compile</code> in Texmaker . . . . .	24
B.4	Function <code>MakeIndex</code> in Texmaker . . . . .	24

## List of Tables

- 2.1 Page margins that have to be observed in the preparation of degree theses. 14

# 1 Introduction

The introduction should present the topic of the thesis to specify the purpose and importance of the work. Other possible contents of an introduction are described in section 2.2.1 on page 8.

## 2 Guidelines for Thesis Composition

Written reports for scientific works, such as degree theses, should feature a certain structure and layout, according to well established standards [2,3], which apply correspondingly also for professional publications of any kind.

Bachelor's or Master's theses must therefore satisfy the Bachelor's or Master's examination regulations.

### 2.1 Structure of the Thesis

Reports on degree theses should have the following contents

- title page,
- abstract,
- text of the original task,
- declaration of authorship of the work and to used aids/tools,
- table of contents,
- list of symbols (optional)
- list of abbreviations (optional),
- list of figures (optional),
- list of tables (optional),
- text of the thesis, roughly structured as
  - introduction,
  - body,
  - summary,
- bibliography,
- appendix (optional),
- statements (for Bachelor's and Master's theses).

Educational references, concerning layout and content of text, figures and tables are given in the following sections.

## 2.2 Contents of the Text

### 2.2.1 Introduction

The introduction is supposed to familiarize the reader with the treated problem and describes:

- the task,
- the current level of knowledge as a basis for the work,
- the aim and the relevance of the work,

and possibly

- the chosen approach,
- the structure of the thesis.

### 2.2.2 Body of the Thesis

The body of the thesis contains a detailed and complete description of the way of problem solving.

An essential aspect is the effective transfer of written information to an educated reader, who is not directly familiar with the problem. This includes

- a clear presentation of the progress of thoughts which leads from the level of knowledge at the beginning of the work to the developed solution,
- a good structure and a logical arrangement,
- an understandable, short and exact formulation without straying from the topic.

The level of knowledge is given by the results of preliminary studies and previous publications. The proposals for the solution of the problem are to be discussed and the chosen approach has to be clearly justified. Essential analysis which does not lead to success has to be added with an explanation. The structure and the order of the text are based on objective criteria not on the temporal sequence of development. The sub-headings should be well chosen. Frequent hints to the path followed place the sections in context.

The description of the studies and experiments have to be detailed enough to allow a replication by others. The results have to be reproducible. All used tools such as literature, formulas, programs or methods of measurement have to be indicated. Adopted results or solutions should be explained only to the extent which is necessary for understanding, with reference to the source but without derivation.

Often measured and calculated results as well as functional correlations can be displayed clearer and more understandably by figures or tables than by long descriptions. Extensive

mathematical derivations or proofs, collections of figures or tables which break the context of a text passage are supposed to be listed in one or more appendices. The text has to include references to all parts of the thesis (figures, tables, literature, attachments).

### **2.2.3 Summary**

The summary as the last section of the text includes clear and critical statements about

- the results of the work and their importance,
- the limits of validity and the progress compared with the level of knowledge at the beginning of the work,
- the applicability of the results and, possibly,
- recommendations for further tasks.

## **2.3 Layout**

### **2.3.1 General Page and Text Format**

Bachelor's and Master's theses have to be printed and filed in page format A4 specified in ISO 216, hardback, also featuring a labeled cover (2 copies). An electronic version of the work should be submitted as a PDF file.

The text must be printed single-sided with a 1<sup>1</sup>/<sub>2</sub> line spacing. The margins have to equal 2.5 cm, except the bottom margin, which has to be 2.0 cm.

Each section of the thesis as listed in section 2.1 starts on a new page. The page numbers of the text body have to continue consecutively throughout the rest of the thesis.

### **2.3.2 Structure**

#### **Title Page**

The layout of the title page is given by a template, according to the title page of this guide.

#### **Table of Contents**

The table of contents consists of the numbered headings of the sections and the corresponding first page numbers. The appendices also have to be listed. The numbering of the pages should start with the table of contents as page 1.

Attention should be paid to a consistent capitalization of the headings in the table of contents. Unclear and uncommon abbreviations should be avoided in the headings.

### **List of Symbols**

A list of symbols should be given if the thesis contains many formulas. All used symbols are to be arranged alphabetically and briefly described.

### **List of Acronyms**

A list of acronyms should be given if the thesis contains many acronyms, especially inside graphics and diagrams. In this list only uncommon acronyms should be given in alphabetical order and should be briefly described.

### **Bibliography**

All used sources of information must be mentioned in the thesis and listed in the bibliography. The referring numbers of the citations are to be set in brackets. The order of numbering of the cited sources has to be according to the order of the first appearance of the citations in the text [4]. When referring to multiple sources a consideration of standardization and uniformity of symbols and abbreviations is needed. If necessary, symbols and abbreviations of cited sources should be adapted to match the entries of the list of symbols and abbreviations in the thesis. Rules for formatting bibliographical reference for different publications are specified in [4]. A reference to sources from the internet is only allowed in special cases, because of the vicissitude and transientness of such sources.

### **Appendix**

The appendices of a thesis should be numbered. Every appendix contains the following introductory information:

- appendix A (consecutively letter),
- title of the appendix,
- index of the appendix (only when the relevant appendix needs structuring due to length).

The following components of a thesis should generally be part of appendices, rather than of the report:

- documentation used in the work like a program lists and scripts, flow charts, descriptions of programs and user information,
- documents for devices that have been constructed during the work, like circuit diagrams, wiring plans, printed circuit board templates, layout diagrams, instruction sheets.

## Statements

Based on the results and conclusions of the work, short and precise statements (ca. 1 to 2 pages) are to be given, addressing the educated reader and encouraging scientific discussion.

The layout of the statements has to be arranged with regard to the given template at the very end of this guideline. Five copies should be submitted along with the printed version of the Bachelor's or Master's thesis.

### 2.3.3 Text Layout

#### Structure

The structure of the text is generated by decimal numeration of the sections. Every section of text must have a headline.

#### References

References in the text to other sections are preferably specified by the corresponding page number. References of the figures, tables and equations have to be identified by the index of the source. These references should be inserted either near the point of the sources in the text or by indicating the page number. Literature references have to be arranged according to their index number in the bibliography. These citation numbers have to appear in the continuous text, not as footnotes. Footnotes should be avoided whenever possible.

#### Citations

The citing of external sources fulfills several purposes:

- to uphold intellectual honesty (and to avoid plagiarism), as extrinsic ideas should be marked as such, and
- to confirm data and facts, the work is based on.

If specific data, facts or texts are referenced in a Bachelor's or Master's thesis, also the source must be mentioned. The pure statement of a fact without citing a source is not admissible. However, a reference is not necessary if the asserted statement is an accepted matter of fact in the special field.

Different types of citations can be distinguished:

1. Direct citations

The verbatim copy of external text parts into the own Bachelor's or Master's thesis is denoted as a direct citation. It is used to analyze or interpret the statement of the cited source. For a direct citation the following points should be observed:

- The citation has to be placed in quotation marks.
- The source has to be cited to the letter.
- The reference to the source follows at the end of the cited text part.
- Text parts in a foreign language should be cited in the original language. They should be amended by a translation that is put in parentheses.
- Own annotations or changes inside the citation should be marked by square brackets. Optional omissions should be marked by square brackets and ellipsis. Example for omissions: “If specific data [...] are referenced in a [...] Master’s thesis, also the source must be mentioned.”

Example for changes: “[A direct citation] is used to analyze or interpret the statement of [a] cited source.”

Citations that are longer than three lines can be indented as a block. In this case no quotes are used.

Example:

This is a longer and comprehensive citation from a certain source that fills several text lines. It is indented as a block in the running text to be indicated as a longer citation.

In many cases not only the content, but also the style of a citation is important. Therefore a direct citation should also copy particular emphasis of the text (e. g. italics, bold text) and the exact punctuation.

## 2. Indirect Citations

The analogous adoption of external text parts or the imitation with regards to the content is denoted as an indirect citation. It is used to support own explanations and positions. Indirect citations are not put into quotation marks. The reference to the source follows the respective text part.

There are other special citations like

- citations in citations, or
- citations to secondary literature,

which are only very seldom used in engineering sciences and therefore not further described here.

Direct and indirect citations can be documented with the exact page number of the original source. The references link to the bibliography. Therefore the following notation can be used:

- The page number can be mentioned inside the square brackets for a direct or indirect citation.

Example: “This is a direct citation.” [2, p. 50]

- If the source ranges over two pages, a “f.” for “and following” is appended to the reference.

Example: “This direct citation [...] goes over two pages.” [2, p. 50 f.]

- If the source ranges over three or more pages, the exact range of pages should be specified.

Example: This indirect citation refers to a longer passage [2, p. 50–55].

- If several, short sources (e. g. article) are cited completely, the references can be directly grouped.

Example: This relation is described in [1–3] in more detail.

## Acronyms

Common acronyms according to the Oxford English Dictionary can be used without explanation, others must be explained when they first appear in the text. Acronyms used in the text and in graphics must be consistent.

## Symbols and Units

For the choice of units the International System of Units (abbreviated SI from French: *Système international d’unités*) is to be regarded. Every symbol must be well-defined when it first appears. Symbols used in the text and in graphics must be consistent. The correct writing of unit symbols and names is explained in the so-called *SI Brochure* [5] of the *International Bureau of Weights and Measures*.

## Equations and Formulas

Equations and formulas should be written on separate lines. Either all or at least all important formulas are to be numbered in parentheses on the right-hand. Equations should be written as quantity equations. If exceptions are necessary, numerical values must always provide their corresponding units. The correct usage of quantities, units and equations is discussed in [6].

When writing formulas, especially for exponents and indices, distinctness must be considered, especially in the following cases:

1. upper and lower case letters,

2. number “0” and letter “O”,
3. number “1” and letter “l”,
4. “k” and “κ” (kappa),  
“n” and “η” (eta),  
“u” and “μ” (my),  
“v” and “ν” (ny).

As an example for correct typesetting and layout the Pythagorean Theorem is used.

$$a^2 + b^2 = c^2 \tag{2.1}$$

Converting into equations for  $a$  or  $b$  results in

$$a^2 = c^2 - b^2 \tag{2.2a}$$

$$b^2 = c^2 - a^2. \tag{2.2b}$$

For multi-line equations the equal signs should be aligned on top of each other.

### 2.3.4 Tables

Numerical tables as well as compilations of data or facts in tabular form have to be numbered consecutively. When referring to certain tables, the abbreviation “Tab.” should be used. There must a (nonbreaking) space between “Tab.” and the number of the table (“see Tab. 2.1” instead of “see Tab.2.1”). Each table has to be labeled with a caption (see Tab. 2.1). Each caption should be unique so that two or more tables never share the very same caption.

The caption has to be placed above the table, as it helps the reader to grasp the content of the table even in the case of a longer table running over several pages. In the head of each column the listed physical quantity has to be clearly indicated by a formula symbol or a word and the corresponding unit.

Table 2.1: Page margins that have to be observed in the preparation of degree theses.

Position	Margin (cm)
left	2.5
right	2.5
top	2.5
bottom	2.0

### 2.3.5 Pictures

Pictures and graphical representations of any kind have to be labeled with a caption and be numbered consecutively (see Fig. 2.1). When referring to certain figures, the abbreviation “Fig.” should be used. There must a (nonbreaking) space between “Fig.” and the number of the figure (“see Fig. 2.1” instead of “see Fig.2.1”).

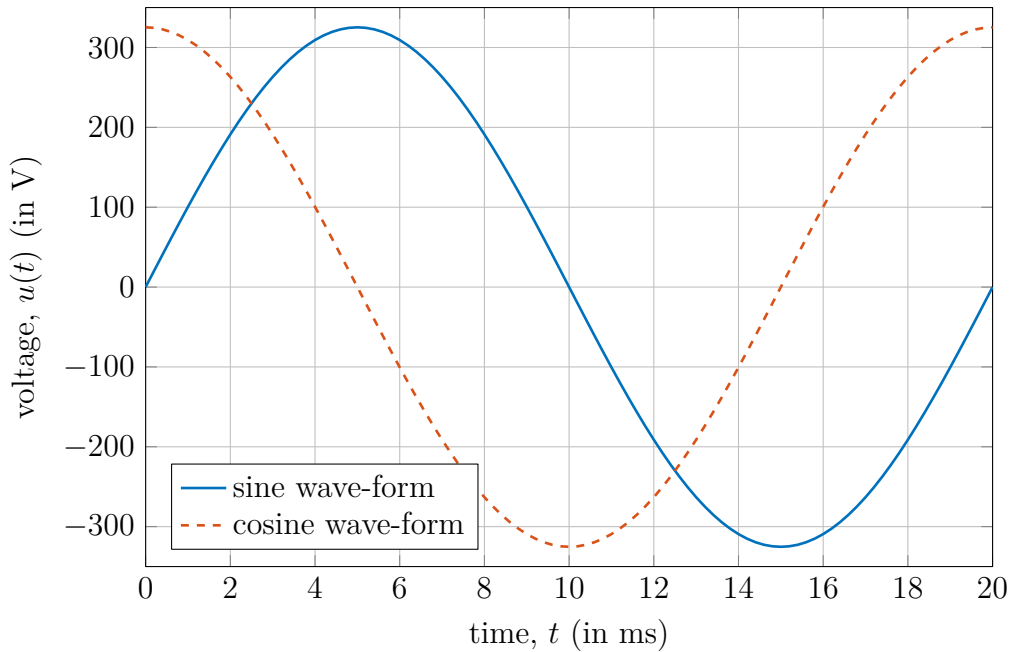

Figure 2.1: Harmonic time course of a voltage with a frequency of 50 Hz and an effective value of 230 V.

Figures that belong together should be placed as sub-figures side by side or one below the other. The sub-figures should be provided consecutively with lower case letters. Two sub-figures placed side by side are exemplary shown in Fig. 2.2. Two sub-figures placed one below the other are shown in Fig. 2.3 on page 16.

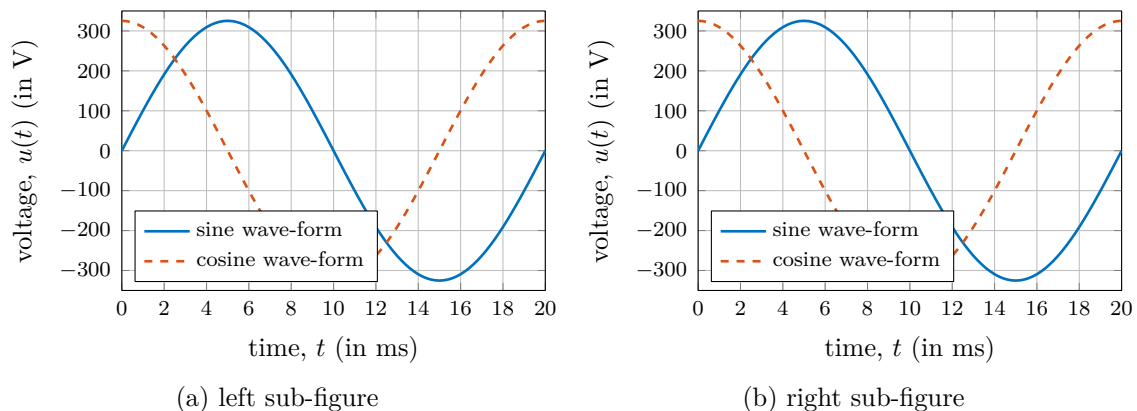
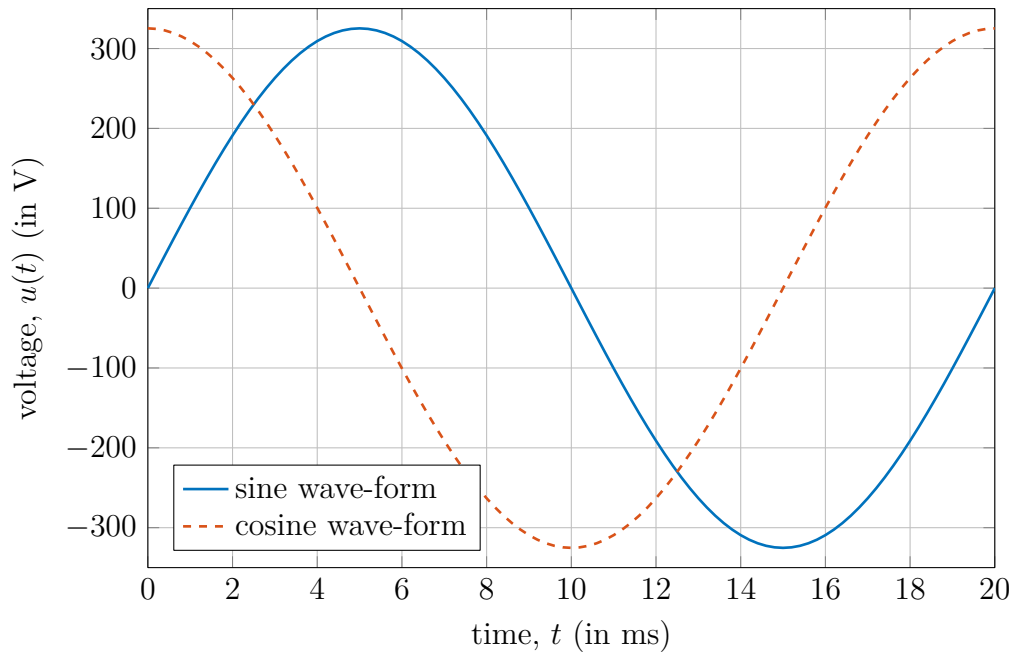
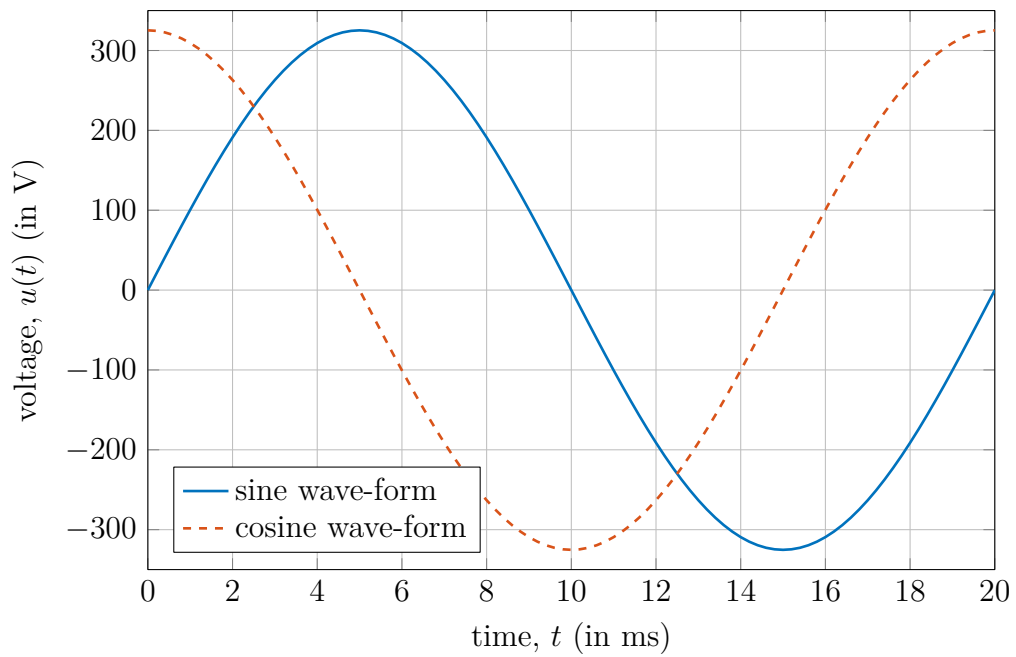

Figure 2.2: Two sub-figures placed side by side.



(a) top sub-figure



(b) bottom sub-figure

Figure 2.3: Two sub-figures placed one below the other.

Figure captions should be self explanatory. Unclear and uncommon abbreviations should be avoided in the figure caption. Explanations that may be necessary to understand the figure should also be given in the caption, for example the meanings of several curves in the same diagram or important boundary conditions under which the curves were obtained. The figure itself should contain the least amount of text as possible.

If a figure is used, that the author has not created himself, the source of the figure should be cited inside or at the end of the figure caption directly below the figure (see Fig. 2.4 for an example). This also applies for figures that have been adapted or modified.

Diagrams, plots and line graphs should be included as vector graphics. Only photographs must be inserted as a bitmap graphic (see Fig. 2.4 for an example).



Figure 2.4: Gradual JPEG artifacts example, with decreasing quality from right to left [7]

The displayed physical quantities in diagrams and plots have to be clearly specific with their corresponding unit. The font size of the axis labels and tick marks must be legible (as in the text). Especially in smaller sub-figures it has to be ensured that the font size is large enough (see Fig. 2.2a and 2.2b). The scale of a diagram has to be chosen in accordance with the accuracy of the presented quantity. The type of division of the grid (e. g. linear or logarithmic) must be plainly apparent. A line spacing smaller than 5 mm for the grid lines should be avoided. A zero suppression of an axis should be clearly marked by a break of the corresponding axis. Curves of statistically fluctuating measured data may be smoothed. Measured points or sparse data points of low density should be printed with a clear signature, e. g. by symbols like +, ×, ○, ●, or \*.

In circuit diagrams, wiring schemes and program flowcharts the usual standardized symbols have to be used. For creating circuit diagrams, the `CircuitikZ` package is useful, see the example in Figure 2.5.

Useful graphical editors for this package can be found on the following websites:

- <https://circuit2tikz.tf.fau.de/designer/>
- <https://app.diagrams.net/>
- <http://www.tikzedt.org/>
- <https://github.com/Bellafaire/CircuiTikZ-Tool>

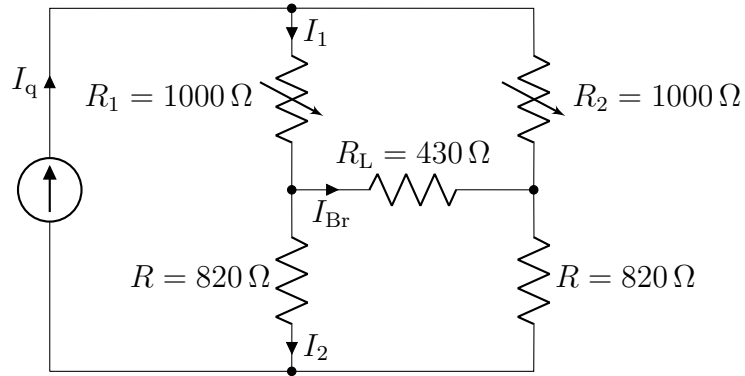

Figure 2.5: Example of a circuit diagram created using CircuiTikZ  
(see also <https://www.overleaf.com/read/skynjttxjhpp>)

### 2.3.6 Lists

Lists and itemizations can be unnumbered like this one:

- foo
- bar
- foobar

There is also a more compact variant:

- foo
- bar
- foobar

Lists can also be numbered as enumerations:

1. foo
2. bar
3. foobar

There is also a more compact variant in this case:

1. foo
2. bar
3. foobar

### **3 Summary**

The summary is the last section of the text and summarizes the results of the work (see also section 2.2.3 from page 9).

## Bibliography

- [1] Wikipedia, the free encyclopedia. (2012, Jan.) Abstract (summary). [Online]. Available: [http://en.wikipedia.org/wiki/Abstract\\_%28summary%29](http://en.wikipedia.org/wiki/Abstract_%28summary%29)
- [2] L. Hering and H. Hering, *How to Write Technical Reports: Understandable Structure, Good Design, Convincing Presentation*. Berlin, Heidelberg: Springer-Verlag, 2010.
- [3] J. Grossman, *The Chicago Manual of Style*, 14th ed. Chicago, USA: Univ. of Chicago Press, 1993.
- [4] *IEEE Citation Reference*, IEEE, New York City, USA. [Online]. Available: <https://www.ieee.org/documents/ieeecitationref.pdf>
- [5] *The International System of Units (SI)*, 8th ed., International Bureau of Weights and Measures (Bureau International des Poids et Mesures), Sèvres, France, May 2006. [Online]. Available: <http://www.bipm.org/en/publications/si-brochure/>
- [6] K. H. Blankenburg, *Standard-compliant usage of quantities, units and equations*, Rohde & Schwarz, Munich, Germany, Feb. 2024, PD 5214.5061.62, Version 06.00. [Online]. Available: [https://scdn.rohde-schwarz.com/ur/pws/dl\\_downloads/pdm/cl\\_brochures\\_and\\_datasheets/brochure/5214\\_5061\\_62/Standard-compliant\\_usage\\_of\\_bro\\_en\\_5214-5061-62\\_v0600.pdf](https://scdn.rohde-schwarz.com/ur/pws/dl_downloads/pdm/cl_brochures_and_datasheets/brochure/5214_5061_62/Standard-compliant_usage_of_bro_en_5214-5061-62_v0600.pdf)
- [7] M. Gäbler. (2011, Oct.) Gradual JPEG artifacts example, with decreasing quality from right to left. via CC BY 3.0. [Online]. Available: <https://commons.wikimedia.org/w/index.php?curid=16857750>

## **A Diagrams**

Possible contents for an attachment as well as its formal design are described in more detail in section 2.3.2 on page 10.

## B Software for Using the LaTeX Document Markup Language

### B.1 Microsoft Windows

MiKTeX: from <http://www.miktex.org/> as a LaTeX back end (don't use the 64-bit version, problems with biber)

SumatraPDF: from <http://blog.kowalczyk.info/software/sumatrapdf/> as a PDF viewer

TeXnicCenter: from <http://www.texniccenter.org/> as a LaTeX front end

JabRef: from <http://jabref.sourceforge.net/> as a BibTeX editor

TortoiseSVN: from <http://tortoisesvn.net/> for version control

XnView: from <http://www.xnview.com/de/> for photo editing

It is recommended to install the software in the order given above.

### B.2 Linux

All necessary programs are usually pre-installed or can be easily installed later via the package manager or software center.

It is recommend to use TeX Live as a LaTeX back end and to use Texmaker as a LaTeX front end with an integrated PDF viewer.

### B.3 Settings for the `nomenc1` Package

The `nomenc1` package is necessary to automatically generate a nomenclature (or list of symbols).

When using the TeXnicCenter, one has to select “Build” in the menu bar and chose the point “Define Output Profiles ...”. The already existing profile “LaTeX => PDF” has to be copied. The copy should be renamed to e.g. “LaTeX => PDF (nomenc1)”. In the field “Command line arguments to pass to MakeIndex:” the entry

```
"%tm".nlo -s nomenc1.ist -o "%tm".nls
```

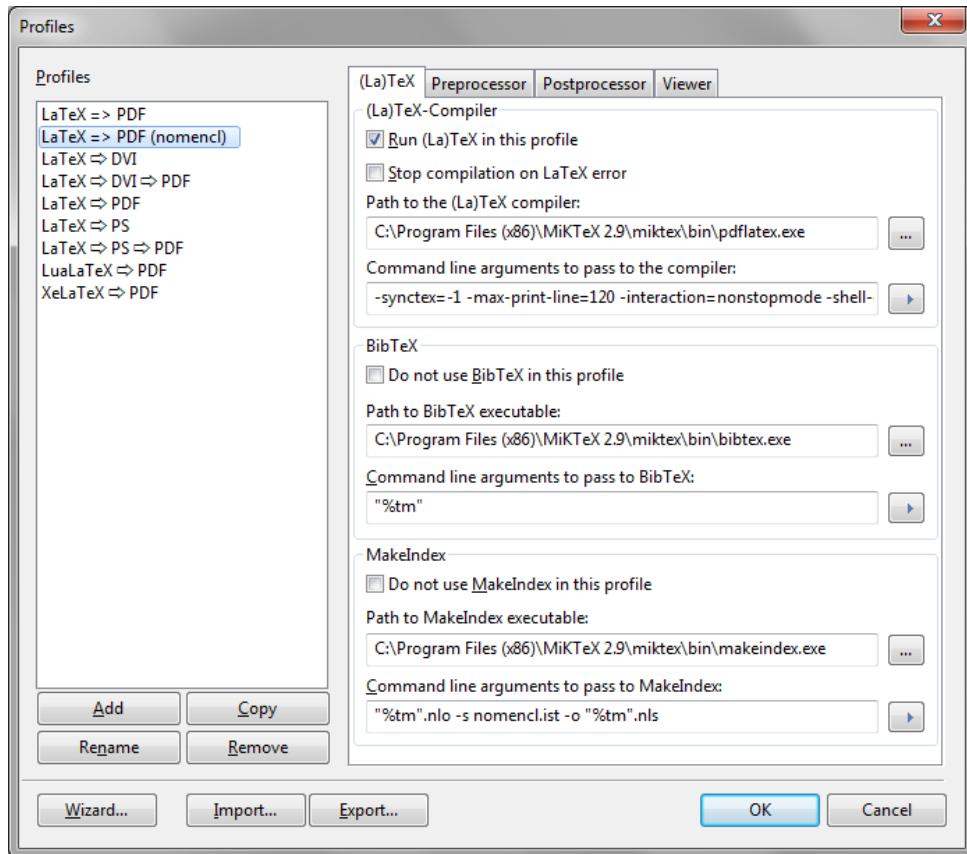

Figure B.1: Settings to use the `nomenc1` package in TeXnicCenter

has to be inserted (also refer to Fig. B.1).

Similar settings have to be made in other editors as Texmaker. The settings required there are shown in Figure B.2. In the field “MakeIndex”

```
makeindex %.nlo -s nomenc1.list -o %.nls -t %.nlg
```

must be entered there.

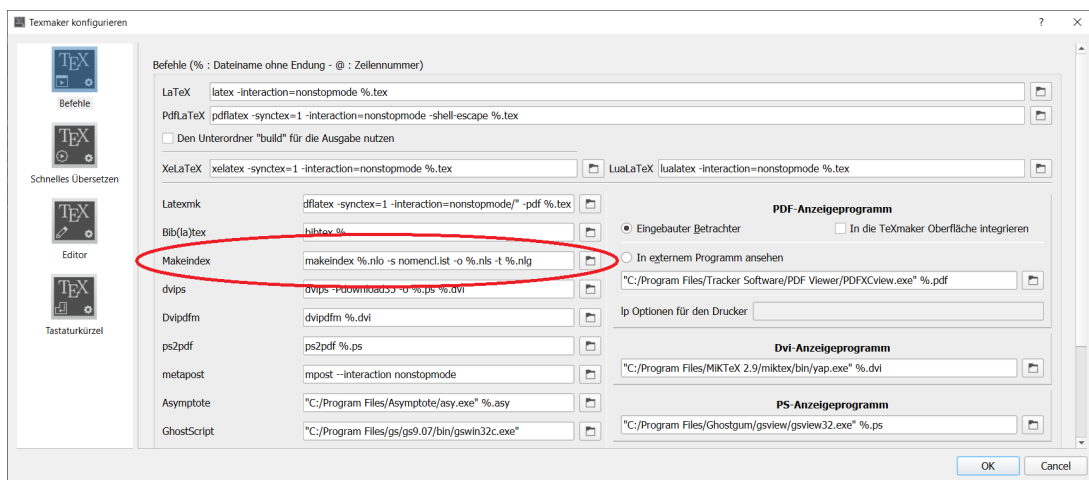

Figure B.2: Settings for using the `nomenc1` package in Texmaker

To create the symbol directory, you must compile the document at least once using the “Quick Compile” function (see Figure B.3), then call “MakeIndex” (see Figure B.4) and compile the document again into a PDF file using “Quick Compile” (see again Figure B.3).

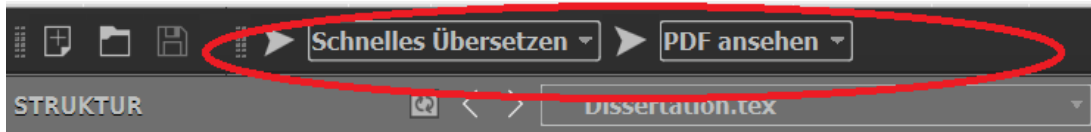

Figure B.3: Function Quick Compile in Texmaker

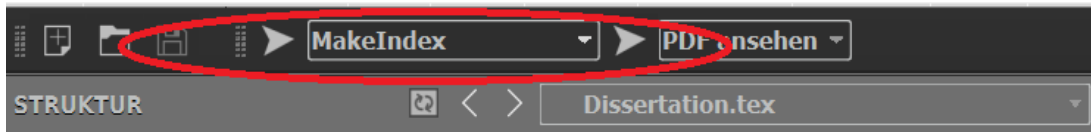

Figure B.4: Function MakeIndex in Texmaker

When creating the document using the Overleaf online editor, no further steps are required to automatically create the symbol directory.

## C Checklists

### C.1 Language

- an automatic spell checker was used to detect typing errors
- proofreading was done by a fellow student
- every sentence starts with a capital letter
- only personal names and proper nouns start with a capital letter, not all nouns
- every sentence ends with a dot, after the dot there is a space before the next sentence starts
- every sentence is written in passive voice
- every sentence is written in the correct tense

### C.2 Mathematical Expressions and Symbols

- every displayed equation was generated in a formula editor, not with the usual text editor
- every displayed equations is centered and consecutively numbered
- all symbols in the running is written in math mode (in Italics)
- all units are written in Roman type (upright) letters
- no “\*” or “x” are used as multiplication signs, only centered dots “.” are used

### C.3 Figures and Tables

- every figure or table has a meaningful and unique caption
- every figure caption is placed below the figure, every table caption is placed above the table
- every caption has a dot at the end
- every figure or table is introduced, referenced, explained and discussed in the text

- all diagrams and schematics are inserted as vector graphics
- all raster graphics have a sufficient resolution
- every figure or table has an appropriate size, the font and font size inside the figure correspond to the font and font size of the surrounding text
- every figure or table is centered with respect to the surrounding text
- all columns in each table have a proper alignment

#### **C.4 Reference and Citations**

- every reference has at least an author (or institution), a title and a date
- every reference is cited at the appropriate position in the running text
- every direct citation is indicated by quotation marks
- there are no citations in the abstract

#### **C.5 Content and Structure**

- no general or introductory information can be found in the abstract, but only information relevant to the specific thesis
- every chapter has an introductory paragraph about the following sections
- every chapter heading or section heading is properly numbered

#### **C.6 Format**

- every paragraph is justified
- every paragraph has the same font and font size
- every itemization or enumeration is formatted with a proper indentation

## D Project Proposal

Managing a research (or integrated) project or writing a degree thesis is a tedious and challenging task. The task sheet given by the supervisor tries to outline the task as exactly as possible, but for brevity cannot include all details, of course. A frequent problem is that students are irritated by the complexity of the task and are unsure about the constructive methodology to solve the given problem.

A thesis proposal at the beginning of the work (after some orientation period) can help the student to get familiar with the topic, to develop own ideas and to get feedback from the supervisors and other experienced researchers working on related topics at an early stage of the work. The student's assumptions and research questions get more focused. Also the validity and reliability of the expected results may be significantly approved, because typical beginner's mistakes in the methodology will be hopefully spotted and corrected. A thesis proposal is also a good exercise on how to convincingly "sell" a project.

Often a thesis proposal has to be prepared as a written document of five to ten pages. At the Otto von Guericke University, Chair for Electromagnetic Compatibility, it is preferred that students give their thesis proposal in an oral presentation of 15 minutes length. The advantages are that a large audience can be addressed in a short time and that very direct feedback can be given in an active discussion.

The presentation should be planned in a way that an educated reader, who is not necessarily a specialist in that particular field of research, can follow the main ideas and can understand the significance of the subject. Nevertheless, the presentation must be sufficiently technically detailed in explaining the planned methodology, so that an expert in that research area will be convinced that the student knows what he or she is doing and that the proposed work is practicable and feasible. It is not expected that any results are presented or rather only preliminary results from some proof of concept.

The following structure or outline might be considered for an effective thesis proposal presentation:

1. Introduction (1 to 2 slides)
  - What is the addressed problem and why is it important?
  - What is the specific scope of the project/thesis?
2. Literature Review and State of the Art (3 to 5 slides)
  - What is the relevant published literature on the topic?

- What are the methodology that were chosen in that publications?
- What are the drawbacks or disadvantages of that methodologies?
- Which problems have already been solved and don't need further attention?

3. Open Research Questions (1 to 2 slides)

- What is the gap in knowledge that has to be filled?
- Which problems are still unsolved (and maybe why)?

4. Planned Work and Methodology (2 to 3 slides)

- What objectives and research techniques shall be employed?
  - What simulation tools might be used?
  - How will a measurement setup look like?
  - What parameters are chosen and why?
  - Which mathematical tools or software will be used for the pre- or post-processing?
- What would be the advantage of the proposed methodology compared with the current state of the art?
- How does the schedule looks like (timetable and milestones for completion)?
- Which special resources are necessary (e. g. special materials, special devices, special software, ...)?
- Which limitations and potential problems may occur?

5. Planned Outcome and Results (1 to 2 slides)

- What are the main planned results or technical outcomes?
- How do these results contribute to the general knowledge in that research area?

6. Conclusion (1 slide)

Student are supposed to give their presentation without a set of notes. If students really need a set of notes, they seem to lack an in-depth understanding of their topic and the proposed work. Students are strongly encouraged to attend the thesis proposal presentations of their fellow students to support them and to learn from their experiences.

# Statements for the Bachelor's/Master's Thesis

## Guidance for the Preparation of Degree Theses

submitted: Month Year

by: John Doe

1. This guidance is a great help for all students who write a thesis for the first time.
2. The brief text pointing to main statements makes it easy to read and understand this guidance within a short time.
3. The consideration of these guidelines expedites the review and appraisal of the thesis by the supervisor and the examiners.
4. ...

Signature